

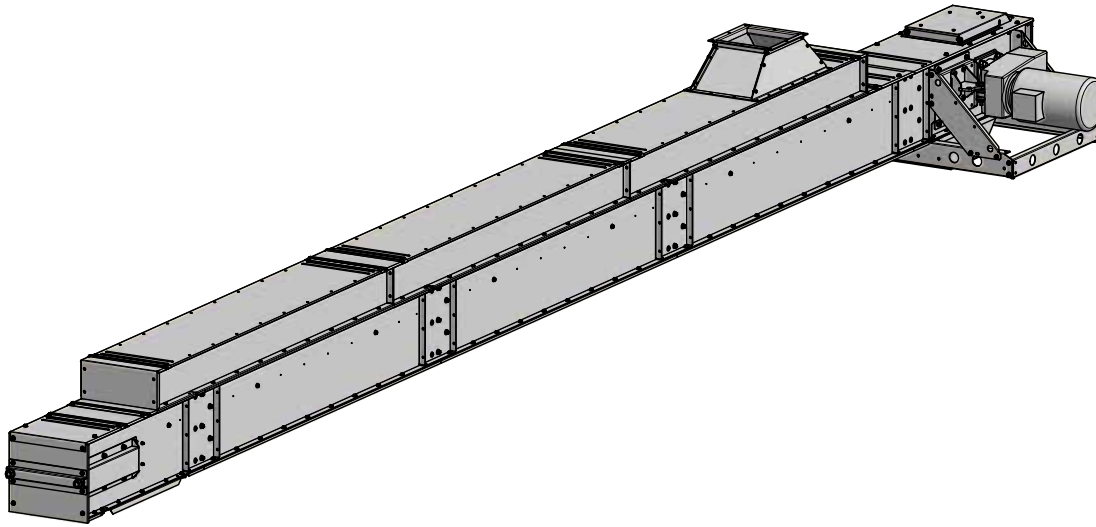

**SKANDIA
ELEVATOR**



Our machines are designed for outdoor use. We only use galvanised steel plate, and join the parts by means of clamp riveting and screwing in order to keep the surface layer intact. Edges are bent down, joints and seams overlap and many parts are embossed in order to prevent water penetration. The most exposed joints are also sealed with rubber strips or silicone. The products in the I-LINE are designed for plants with continuous operation all year round.



KTIF/FR

The top conveyor KTIF/FR is a flow/return conveyor with a capacity adapted to convey material from a Skandia elevator to storage bins/silos.

STANDARD EQUIPMENT:

- › Direct-mounted gearbox motor with support frame
- › Pop up overloading flap/inspection hatch with safety switch
- › Intermediate sections with raised lid and intermediate tray
- › Inlet hopper/Outlet hopper
- › Chain tensioner with variable end face for extra cleanliness
- › Bottom clean out hatch in tail end
- › Chain return rollers of PA6G (Polyamide Glass Fibre Reinforced)
- › Permanently lubricated bearings
- › Chain and flight of steel with flight casing of PE (polyethylene)

ACCESSORIES:

- › Weather cover for gearbox motor
- › Connections, hoppers & valves for different needs
- › Transverse or in line outlet slide with brush (manual, electrical or pneumatic)
- › Weather cover for outlet slide
- › Chain guard
- › Chain with return buckets
- › Inspection glass for intermediate sections
- › Wire support for up to a 12 metre span



Pop up overloading flap/inspection hatch with safety switch.

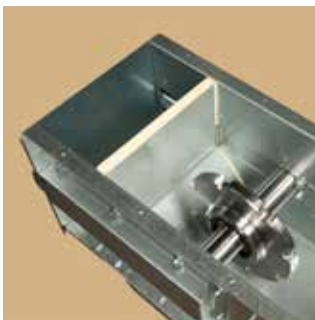

Variable end face for extra cleanliness.

**GALVANISED
ENERGY EFFICIENT
SERVICE FRIENDLY
COMPACT
RELIABLE
EASILY MOUNTED**



**THE
LEADING
COMPANY**



Direct-mounted gearbox motor with support frame.

KTIF/FR

DIMENSIONAL DRAWING

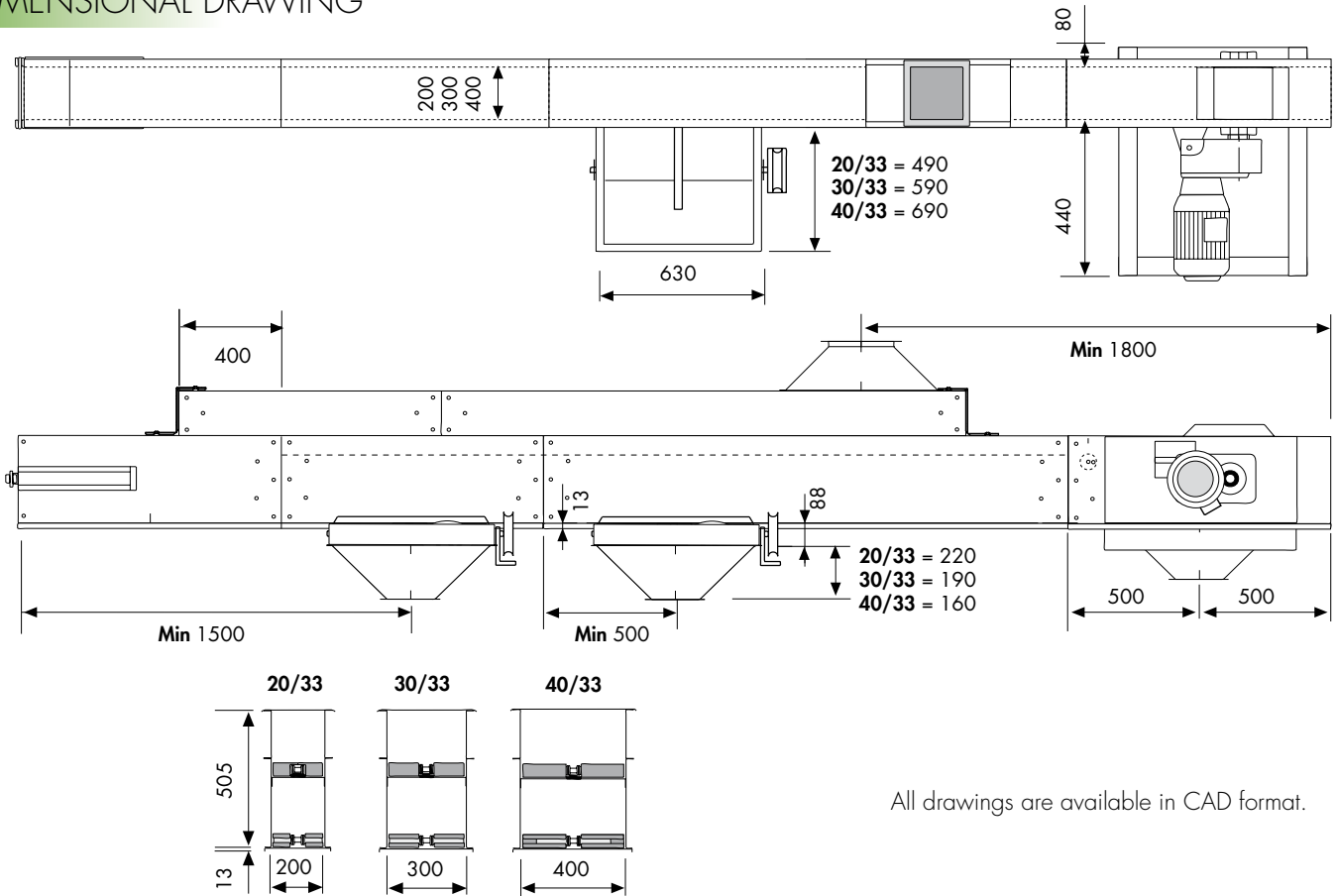

All drawings are available in CAD format.

KTIF/FR TOP CONVEYOR

		20/33	20/33	30/33	30/33	40/33	40/33
		40 t/h	60 t/h	80 t/h	100 t/h	120 t/h	150 t/h
Capacity for 750 kg/m ³	t/h	49-54	66-71	89-96	110-117	135-148	158 - 164
Capacity	m ³ /h	65-72	88-95	119-128	147-156	180-197	211 - 218
Speed	rpm	32-35	43-46	38-41	47-50	43-47	50 - 52
Chain speed	m/s	0.43-0.47	0.57-0.61	0.51-0.55	0.63-0.67	0.57-0.63	0.67 - 0.69
Conveyor chain, type		M80					
Pitch/ultimate tensile strength		100 mm/80 kN					
Chain sprocket, teeth	pcs	8					
Flight, material		Steel/Plastic					
Intermediate section, width/height	mm	200/335		300/335		400/335	400/335
Plate thickness drive, side plate/bottom plate	mm	5.0/2.5					
Plate thickness tail end/intermediate section, side/bottom plate	mm	2.5/2.5					
Inlet and outlet hoppers	mm	3.0/□180		3.0/□250		3.0/□300	3.0/□300
ATEX class (standard equipment)		II 2D/0D					

